



CM3000

ChangeMaker



Operator's Manual

Seaga Manufacturing, Inc.
700 Seaga Drive
Freeport, IL USA 61032
www.seagamfg.com

INTRODUCTION

Congratulations on the purchase of your new ChangeMaker. This ChangeMaker has been designed to give you many years of dependable service. It requires little maintenance and is easy to set up and operate.

READ THIS MANUAL COMPLETELY

Your ChangeMaker is designed to operate simply and reliably, but to take full advantage of your vendor, please read this owner's manual thoroughly. It contains important information regarding installation and operations, as well as a brief troubleshooting guide.

EQUIPMENT INSPECTION

After you have received your ChangeMaker and have it out of the box, place it on a secure surface for further inspection. **Note:** Any damages that may have occurred during shipping must be reported to the delivery carrier immediately. Reporting damages and the seeking of restitution is the responsibility of the equipment owner. The factory is willing to assist you in this process in any way possible. Feel free to contact our Customer Care Department with any questions you may have on this process.

Once you have your vendor located, we suggest that you keep this manual for future reference, or you can view this manual online at www.seagamfg.com. Should any problems occur, refer to the section entitled "COMMON QUESTIONS AND ANSWERS". It is designed to help you quickly identify a problem and correct it.

MANUFACTURER'S WARRANTY

WHAT IS COVERED:

Manufacturer warrants TO THE ORIGINAL PURCHASER ONLY that each item of equipment manufactured is free from defects in material and workmanship under normal use and service. Manufacturer's obligation under this warranty shall be limited to repair or replacement, at our plant, of any parts of the equipment which shall, within one year of the date of shipment to the original purchaser, be demonstrated to be defective. The original purchaser may obtain repair or replacement of the equipment under this warranty by returning the defective item or entire vendor to the Manufacturer, freight pre-paid.

WHAT IS NOT COVERED:

Manufacturer's warranty obligations DO NOT EXTEND TO OR INCLUDE installation expenses, vandalism, or difficulties resulting from failure to operate equipment in accordance with Manufacturer's instructions under competent supervision and difficulties due to changes in vended products which are beyond the control of Manufacturer.

SPECIAL NOTE: Manufacturer is not responsible for any loss of income due to a vending machine being out of service due to a warrantable item.

This warranty is in lieu of all other warranties, expressed or implied, including the warranty of merchantability and fitness or use, and of all other obligations or liabilities on Manufacturer's part. Manufacturer neither assumes, nor authorizes any other person to assume for it, any other liability in connection with the sale of equipment manufactured by itself. This warranty shall not apply to equipment manufactured or any part thereof which is subject to accident, negligence, alteration, abuse, misuse or damage in shipment. The term "original purchaser," as used in this warranty, shall be deemed to mean that person for whom the equipment is originally installed.

Manufacturer is not liable for any incidental, consequential or other damages of any kind whatsoever, directly or indirectly, arising from the use of the equipment whether based upon theories of contract negligence or tort.

Effective 9/01

For Technical Support & Service

Contact our Customer Care Dept.

8:30 a.m. - 4:00 p.m. CST. Mon thru Fri
800.444.1954 ext 160, Domestic
815.297.9500 ext 160, International
815.297.1758 Fax
email: customercare@seagamfg.com

For Parts

Contact our Parts Dept.

8:30 a.m. - 4:00 p.m. CST. Mon thru Fri
800.444.1954 ext 160, Domestic
815.297.9500 ext 160, International
815.297.1758 Fax
email: parts@seagamfg.com



Seaga Manufacturing, Inc.

700 Seaga Drive

Freeport, IL 61032 U.S.A.

Online: www.seagamfg.com

ChangeMaker CM3000

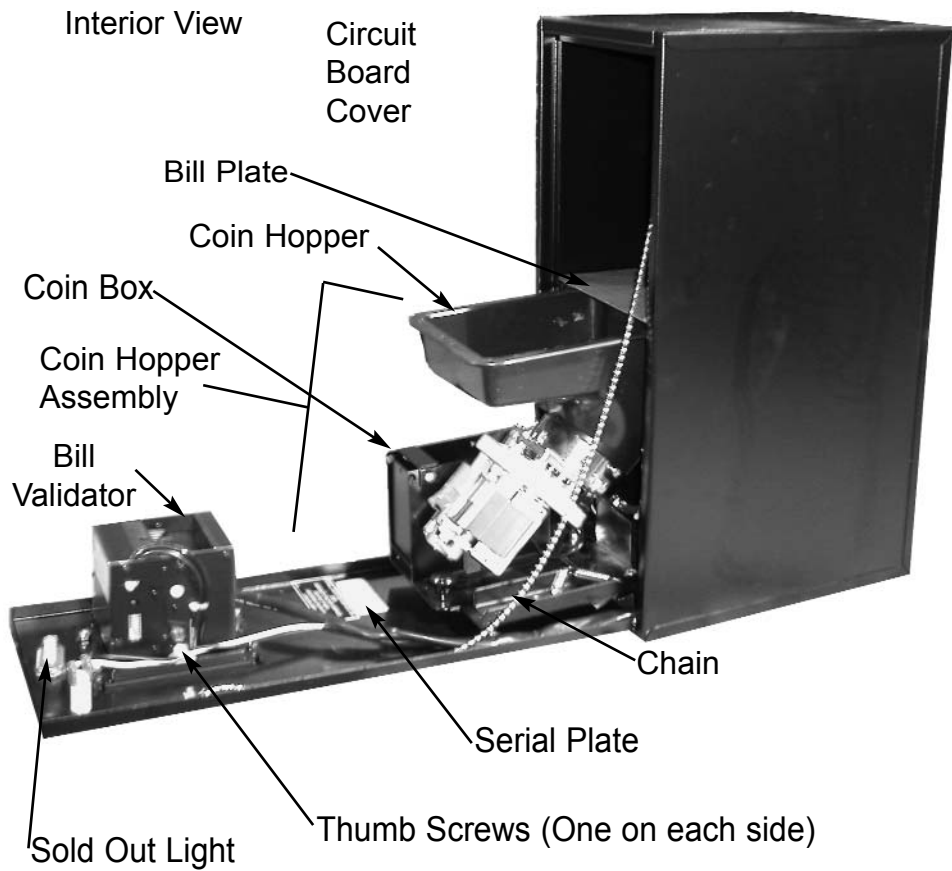
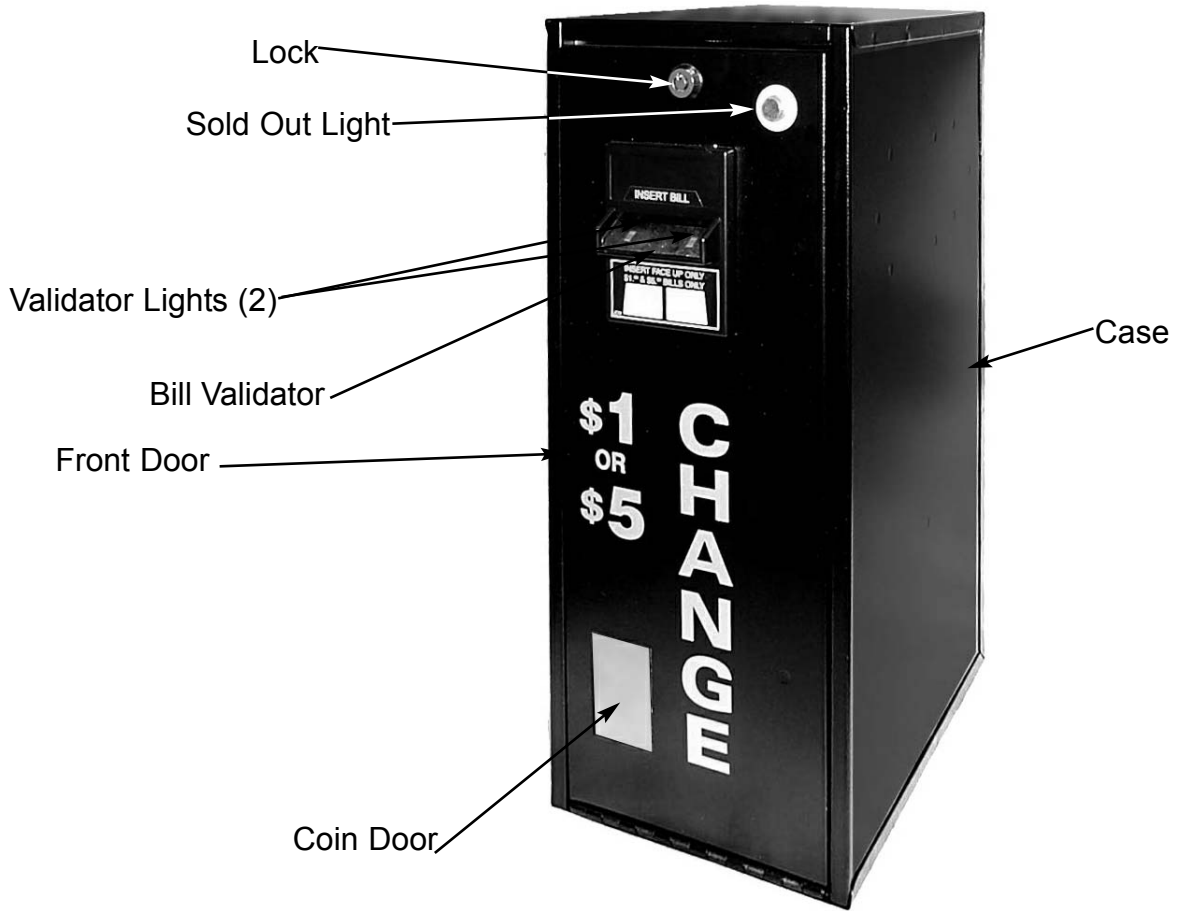

LOCK

Your ChangeMaker has one (1) Lock. To unlock the Front Door, turn key counter-clockwise one-quarter turn. The Front Panel will now swing open. A Chain attaches the Front Door to the Body for support. You will not be able to remove the key once the ChangeMaker is unlocked.

MOUNTING

The Changemaker has three (3) plugged holes in the left-hand side of the Case for optional mounting. A drill, a ¼" drill bit, and two (2) wrenches will be required. A mounting template for drilling holes is provided.

1. To Mount:

- A.) Secure the template to the mounting surface once you have made sure that nothing will obstruct the drilling of holes or the placement of bolts.
- B.) Drill holes. Discard Template.
- C.) Unlock and open the Front Door.
- D.) Pull Coin Hopper Assembly forward. Disconnect the wires that connect the Coin Hopper Assembly to the inside of the case. **Note:** The Coin Hopper Assembly will still be connected to the Bill Validator.
- E.) Remove the three (3) Plugs by pushing them out from inside the Body.
- F.) Attach the ChangeMaker to surface with hardware provided by inserting the bolts through from inside the ChangeMaker into the mounting surface. **Note:** Hardware provided may not be suitable for all mounting applications. Pull Coin Hopper Assembly forward to access the lower rear hole.
- G.) Slide Coin Hopper Assembly back in and close front door.

SETTING SERVICE

Your ChangeMaker is factory preset to validate \$1 and \$5 bills. Inside the Front Door, on the right hand side of the Bill Validator you will find the Setting Switches. The Setting Switches are factory preset with #1 and #3 up. Your ChangeMaker may dispense tokens as long as they are close to the size of a quarter. No changes are needed for your ChangeMaker to return tokens to your customers. You also have the ability to return more than 4 tokens to your customer per dollar. The following Diagram illustrates how to make these adjustments.

Figure 1 Setting Switches

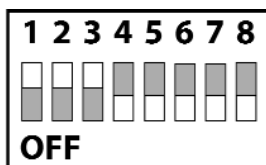

Factory Preset \$1 and \$5, 4 coins per \$
Switches 1, 2, & 3 up (on)

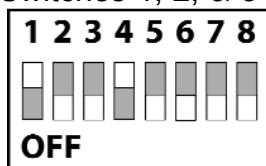

Optional setting: 5 coins per \$
Switches 1 & 4 up (on)

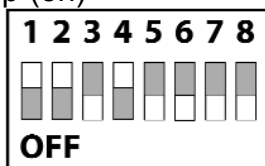

Optional setting: 8 coins per \$
Switches 1, 2 & 4 up (on)

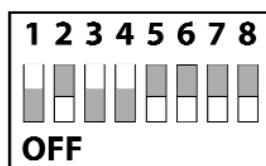

Optional setting: 10 coins per \$
Switches 1, 3, & 4 up (on)



Optional setting: 20 coins per \$
Switches 1, 2, 3, & 4 up (on)

DELIVERY SYSTEM

The ChangeMaker Delivery System consists of the Bill Validator and the Coin Hopper Assembly. The Coin Hopper Assembly is made up of the Coin Hopper, Base, Coin Plate, and the Drive Motor. The Coin Hopper holds quarters in bulk, the Bill Validator accepts bills and cycles the Coin Plate dispensing the needed amount of coins through the Coin Counter until the correct amount of coins are dispensed. It is possible that your Coin Dispensing Plate may come loose and cause your ChangeMaker to give the wrong amount of coins to your customers. To adjust the Coin Dispensing Wheel, you will need to adjust the set screws that secure the Coin Dispensing Plate to the Axle, just below the Collar. You will need a 2.5 mm allen wrench. Loosen the set screws and lightly tap the Coin Dispensing Plate down onto the base and tighten the set screws.

1. To Remove Coin Hopper Assembly:

- A.) Unlock and open the Front Door. You will want the ChangeMaker to the edge of a counter, so the Front Door opens as far as possible.
- B.) Slide the Coin Hopper Assembly forward until it is stopped by the Latch. Push the Latch in and continue to pull the Coin Hopper Assembly forward as far as the track will allow.
- C.) Disconnect the wiring harness from the Coin Hopper Assembly to the Circuit Board.
- D.) Reach below the track, there is a black plastic catch that must be pushed left to release. Once pushed, the Coin Hopper Assembly can be removed from the Case.

Figure 2 Coin Hopper Assembly

Coin Hopper
Assembly shown
from behind

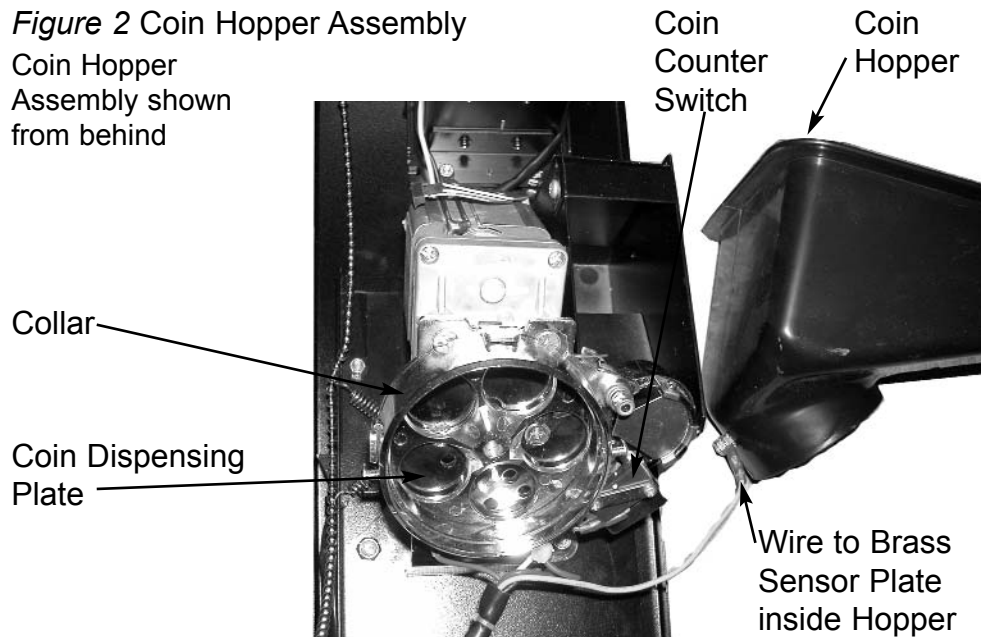

LOADING CURRENCY

The Coin Hopper holds your quarters (or tokens) in bulk. To load, pour quarters into the Coin Hopper until full.

CAPACITY

Your ChangeMaker has a change capacity of \$300.

BILL RETRIEVAL

Accepted bills are stored in the Case on top of the Divider Plate.

SOLD OUT LIGHT

The Sold Out Light will be illuminated when there are approximately 20 quarters in the Coin Hopper. The Sold Out Light will also flash in the event of electrical faults. If your Coin Hopper has plenty of quarters, and the Sold Out Light is flashing, unplug the ChangeMaker for about one (1) minute to reset.

CLEANING

It is recommended that you clean your Bill Validator monthly to keep it in proper working order. In high traffic, or locations that are excessively dusty or dirty, you may need to clean your Bill Validator more often. Cleaning the Bill Validator can correct problems with service. There are three (3) levels to the cleaning process. Cleaning with a cleaning card, cleaning the Optics, and washing the Lower Housing.

1. Cleaning with a Cleaning Card will perform a basic clean. The ChangeMaker does not need to be opened. One (1) Cleaning Card is provided with your ChangeMaker but more can, and should be purchased. Seaga Manufacturing recommends CLEAN TEAM cards that can be obtained online at www.cleanteam.com or by calling 1-800-888-8830.

A.) Insert the cleaning card in the same manner you would a regular dollar bill. The card will be rejected.

2. Cleaning the Optics is the second level of cleaning. You will need cotton swabs (Q-tips), and a mild soap and water solution.

A.) Unplug the ChangeMaker.

B.) Unlock and open the Front Door.

C.) Unplug the wire harness from the left side of the Bill Validator.

D.) Loosen the two (2) Thumb Screws on either side of the Bill Validator. You may need a standard screwdriver, or pliers.

Note: The Thumb Screws have a collar below the head, so they will need to be loosened past the collar.

E.) Tilt open the Bill Validator.

F.) There are three (3) large clear lenses on the Lower Housing and three (3) small clear lenses and a silver Sensor on the Upper Housing. Swab the lenses and the Sensor with the solution and reassemble.

3. Washing the Lower Housing is recommended at least once per year. You will need a mild soap and water solution and a cloth.

Figure 3 Cleaning

Bill Validator
shown open

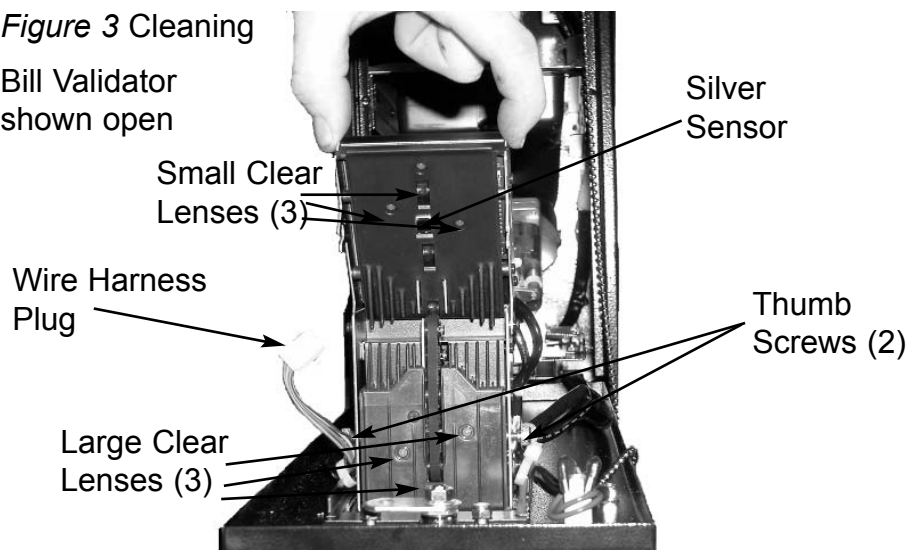

A.) Perform steps A-E as described above.

B.) Moisten the cloth. You will want the cloth moist, but not dripping.

C.) Wipe down the inside of the Bill Validator thoroughly, and reassemble.

4. The Coin Hopper and Brass Sensor Plate may need to be cleaned periodically. To clean Hopper and Sensor Plate, use a cotton towel dampened with warm water only and wipe dry immediately. Do

not use cleaners or chemicals on the Brass Sensor Plate.

REMOVING THE BILL VALIDATOR

In the event that you need to replace your Bill Validator, your ChangeMaker is designed for easy replacement.

1. To Remove the Bill Validator.
 - A.)Unplug the ChangeMaker.
 - B.)Unlock and open the Front Door.
 - C.)Unplug the Wiring harness from the left side of the Bill Validator.
 - D.)Remove the four (4) Mounting Nuts (Fig. 4) that secure the Bill Validator to the inside of the Front Door.
 - E.)Remove Bill Validator and replace. Repeat the above steps in reverse order to reassemble.

Figure 4 Bill Validator Removal

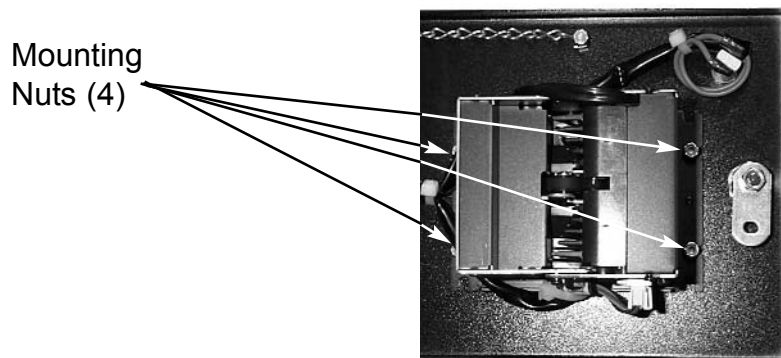

CLEARING JAMS

Coins may become jammed in the Coin Hopper for many reasons, dirt, debris, deformed coins, etc. One of the easiest methods to clear a jam is to turn the Coin Dispensing Plate manually. You will first need to remove all the coins you can from the Coin Hopper. To turn the Coin Dispensing Plate manually, depress the Brake and turn the Driver Motor's Axle. (Fig. 5) turn the Axle clockwise with your fingers, this will reverse the Coin Dispensing Plate. Remove and discard the obstruction. To remove a jammed bill, open the Bill Validator per "CLEANING" and remove the jam.

Figure 5 Turning the Coin Plate

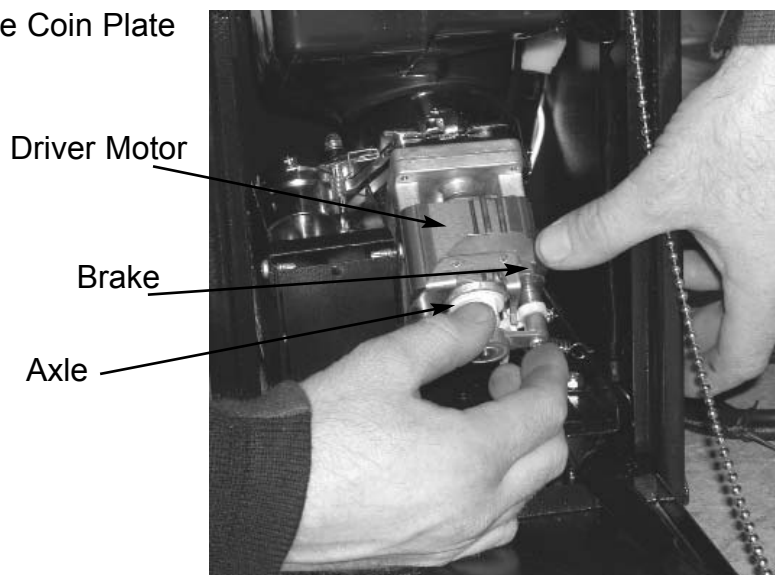

GENERAL

It is suggested that a toolbox accompany you to each of your locations. Suggested items for this toolbox would include a socket set, (up to a 1/2" socket size suggested) a wrench or pliers, a Phillips and a Standard screwdriver. Additional items would be a soft rag and perhaps a Black Magic marker. The magic marker is useful in touching up light scratches that may occur to your ChangeMaker.

COMMON QUESTIONS AND ANSWERS

- Q: The Validator Lights do not light
A: Check the power source.
Unplug the ChangeMaker, then wait one (1) minute and plug back in. (This action will "reset" the ChangeMaker.)
Check the Wire Harness to make sure it is plugged in to the Bill Validator.
- Q: The Validator Lights and/or Sold Out Light flash.
A: Check the level of coins in the Coin Hopper.
Check for jammed coin or bill. (See Clearing Jams)
Check the wiring connections to the Coin Counter Switch.
Check the Wire Harness plug that connects the Coin Hopper.
- Q: How do I remove a jammed bill?
A: Open the Bill Validator (see Cleaning) and remove the jam.
- Q: Bill will not feed into, or is not accepted by the Bill Validator.
A: Make sure that the bill is not soiled, damaged or defaced.
Check for a jammed bill (See Clearing Jams)
Clean the Bill Validator.
- Q: My ChangeMaker is dispensing the wrong amount of coins.
A: Make sure that the coins are not damaged, obstructed or stuck together.
Check the wiring connections at the Coin Counter Switch.
The two wires must be connected to the outermost posts.
Make sure that dispensed quarters trigger the Coin Counter Switch. If they do not, your Coin Dispensing Wheel may have come loose. (See Delivery System)